

N° de l'apprenti

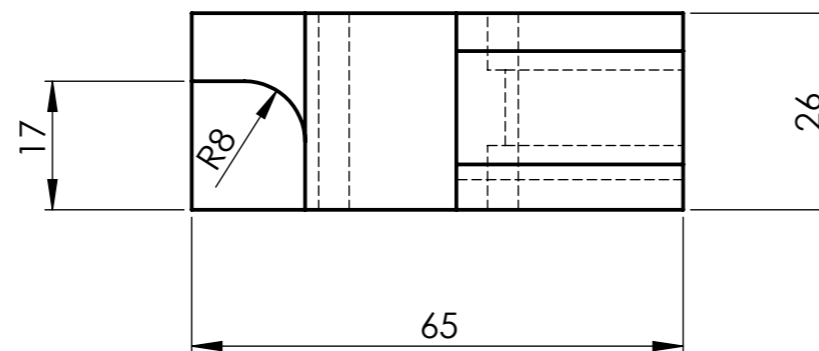
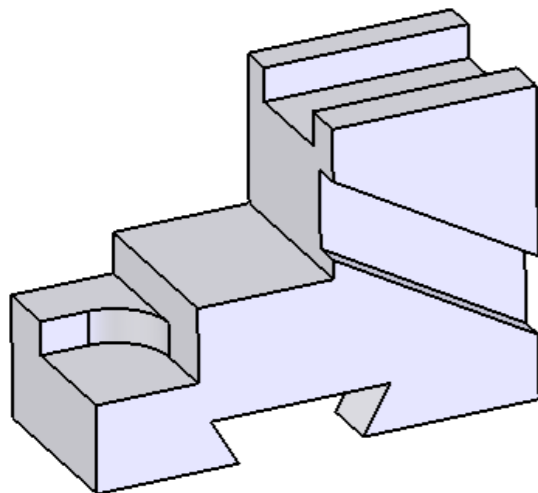
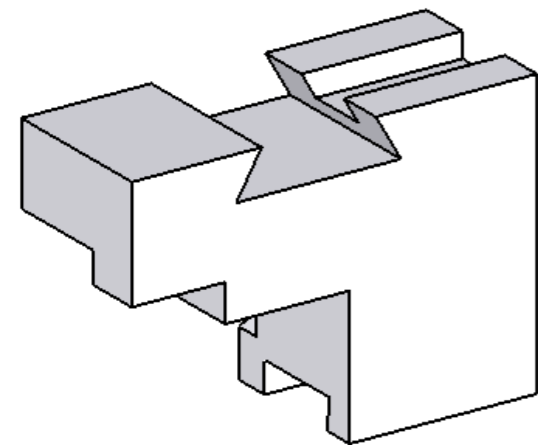
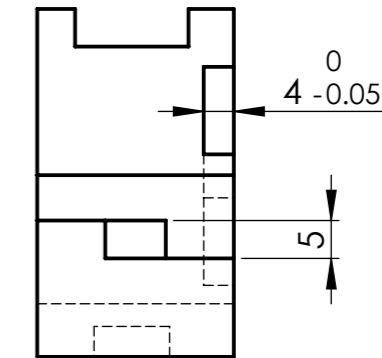
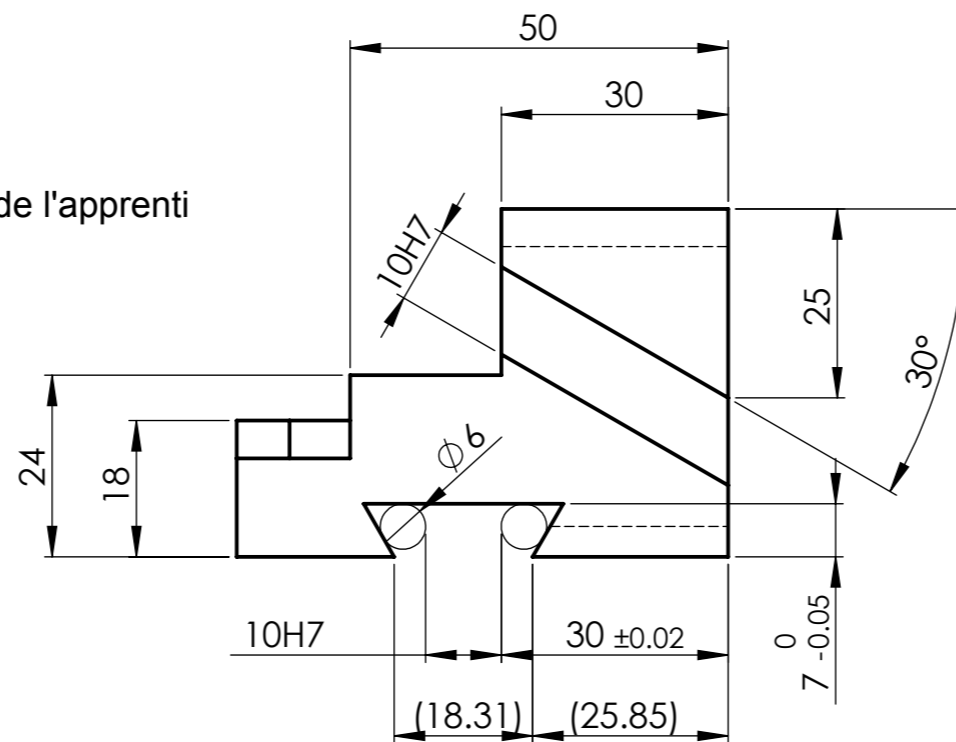

1. Chanfreiner 0.3 x 45°
Ra 1.6

Tolérances générales ISO 2768-1m

1	Plaque	1	Fonte GG20	50 x 30 x 68
Nbr.	Spécifications	Pos.	Matière	Dimensions
Début de l'usinage :			Temps alloué : 4,5 heures	
Fin de l'usinage :			Temps effectif :	
Pièce d'exercice				Echelle
				Dessiné : JJ Genetti
				Date : 27.09.2010
				No.:
			
Centre de formation vaudois de l'industrie				CFVI FR-4